

MULTI-SUBSTRATE
OFFSET by *sleeve*
COMBINATION PRINTING

X FLEX
OMET X6
OFFSET SLEEVE



TOP PRINTING QUALITY WITH VARIABLE SIZE **OFFSET** by *sleeve*



XFlex X6 **OFFSET** by *sleeve* is a platform on which interchangeable technologies produce labels and flexible packaging of the highest quality. Standardization and print consistency are a stringent need of printers worldwide. The combination of flexo+offset represents a key to their success introducing the advantages of both technologies combined with many additional equipment for in-line, efficient printing. XFlex X6 **OFFSET** by *sleeve* press is extremely flexible and accepts a wide range of substrates.

The new **OFFSET** by *sleeve* unit introduces the real offset variable repeat technology, which means fast and completely automatic change of repeat on the shortest web path. Sleeve technology introduces as well the concept of 'low cost repeat change'.



XFlex OFFSET by *sleeve* Specifications



	340	430	530
Max Speed	200 m/min	200 m/min	200 m/min
Unwinding roll diameter	1000 mm (40")	1000 mm (40")	1000 mm (40")
Web width	340 mm (13" 3/8)	430 mm (17")	530 mm (20,8")
Print width	330 mm (13")	420 mm (16,5")	510 mm (20")
Infeed / outfeed	servo driven		
Printing axes	independent direct driven motor, gearless technology		
Cross registration	servo, +/- 5 mm		
Longitudinal regulation of print	360°		
Intelligent automatic pre-register	VISION 1 (Optional)		
Print repeat (infinitely variable)	14" - 25" (355-635 mm)		
Printing plates technology	plates mounted on sleeves		
Register control	integrated (optional)		
AVAILABLE PRINTING TECHNOLOGIES			
OFFSET by <i>sleeve</i>	14" - 25"	14" - 25"	14" - 25"
Flexo UV	12" - 25"	12" - 25"	12" - 25"
Flexo Water Base	12" - 25"	12" - 25"	12" - 25"
Rotary screen (interchangeable cassette)	12" - 18"	12" - 18"	12" - 18"
Rotogravure	12" - 25"	12" - 25"	12" - 25"
Turning bar	•	•	•
Print on adhesive	•	•	•
Hot-Air (Dryer interchangeable position)	•	•	•
FINISHING, WITH MOVABLE ELEMENTS			
Overhead Rail System, for easy press reconfiguration	•	•	•
Cold Foil (sliding on rail)	•	•	•
Hot Foil (sliding on rail)	•	•	•
UV Lamination Unit (sliding on rail)	•	•	•
Delam/relam Unit (sliding on rail)	•	•	•
Web Turn bar (sliding on rail)	•	•	•
Peel & Seal Unit	•	•	•
CONVERTING			
Die-cutting section	Max 25"	Max 25"	Max 25"
Matrix Rewinder with servo tension control (with contact rider roll)	760 mm (30")	760 mm (30")	760 mm (30")
Monotwin Cut	•	•	•
SUBSTRATES			
Film from 12 microns	•	•	•
Unsupported paper	•	•	•
PS material	•	•	•
Carton	•	•	•
OTHER TECHNICAL INFORMATION			
Rewinders diameter	2 x 760 mm or 1 x 1000 mm		
Rewinders	independent motor, taper tension, constant tension		



Flat Bed Hot Foil & Embossing Unit

Thanks to its turning foil head, this Flat-Bed Hot Foil and Embossing unit delivers cost-efficient production of complex designs in one pass on OMET's XFlex X6 printing machines, with the superior quality of flat-bed technology. The unit can be used with low-cost flat-bed foils on rotary presses and flat embossing tools, thus involving savings in material cost. In addition, a special foil saving system reduces the overall material supply.



OFFSET by *sleeve* UNIT FEATURES:

- The unit accepts both aluminum or polyurethane/fiberglass sleeves. They are light sleeves, easy to handle
- The ink train roll system counts 21 rolls and a deviation system that allows an increased ink flow and improves printing quality at the highest speed rates
- Infinitely variable print repeat ranging from 14" to 25", the widest on the market. The smallest sizes allow a lower cost of the offset and flexo sleeves, whilst reducing the cost of the plates, photopolymers and further ancillary equipment
- Fully automatic sleeve change
- Extremely reduced web path with UV installed on chill drum
- Independent motors on the repeat sleeves and on the chilled impression cylinders
- Anti-ghosting system added in the inking train
- Compact and totally rigid printing unit, with one single mobile center: the blanket cylinder
- Absence of axes and parts placed on sliding guides/rails to avoid vibrations
- Print adjustments performed completely outside the unit
- Remote control of the ink fountain blades, straight from the console
- Dampening system with independent motor at variable speed

Ink fountain blade consisting of independent, fully MOTORIZED sectors



Remote ink color control system



Color and dampening controlled from panel



Plate and blanket sleeves



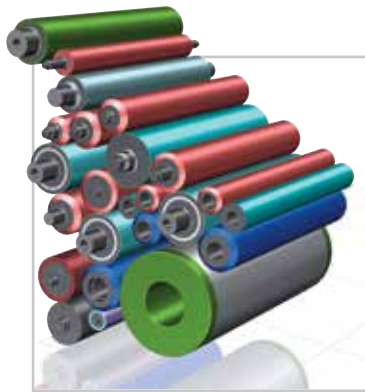

- Ink train roll system with 21 rolls + ink roll deviation system.

ADDITIONAL EQUIPMENTS



- Aluminum or polyurethane sleeves suitable with **OFFSET** by *sleeve* units.



OFFSET by *sleeve* trolley

OMET's **OFFSET** by *sleeve* is the first printing unit which allows the use of both aluminum and polyurethane sleeves. A special trolley has been designed to hold the sleeves in the smartest way possible. The trolley can be moved alongside the press to speed up sleeve change.

- Automatic pre-register, longitudinal and transversal
- Vision system for automatic tight registration of the entire printing section simply by pressing one button
- Inking roller and ink fountain roller with temperature control
- Touch-screen panel located on each printing unit
- Automatic rolls washing with no need of the operators' intervention
- Ergonomics: unit accessible by the operator from both sides
- Use of FEA (Finite Element Analysis) software: analysis for final sizing and dimensioning check of the whole project after completion of the groups
- Sleeves movable on trolley

OFFSET PRINTING ADVANTAGES:

- Undisputed print quality
- Standardization
- Uniformity of printing for the entire run
- Limited cost of the plates
- Available service support, trained staff and pre-press centers everywhere in the world!
- The new software and the interlocking reduce set-up times and waste dramatically
- Superior flexibility in ink management

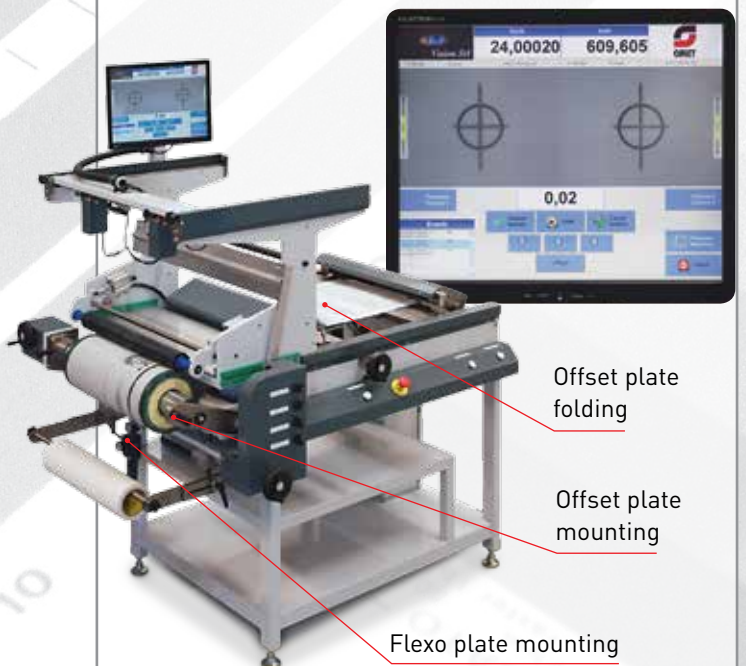

Plate Mounting Offset + Flexo

New plate mounting with advanced plate alignment vision system during the folding and mounting phases. Plate mounting is universal on flexo and offset.



OMET Srl

Via Caduti a Fossoli, 22 - 23900 Lecco - ITALY - Tel. +39 0341 282661 - Fax +39 0341 363731
comm@omet.it - www.omet.com - www.archipelago.omet.it

OMET Americas, Inc.

1273 Rand Road, Des Plaines, IL, 60016 - USA
Tel. +1 847 3768283 - Fax +1 847 3768643
service@ometamericasinc.com
sales@ometamericasinc.com

OMET Iberica I&C S.L.

Calle Provenza, 196
08036 Barcelona - SPAIN
Tel. +34 66 9789946 - Fax +34 93 4907740
ometiberica@terra.es

OMET Suzhou Mechanical Co., Ltd

No. 255 Quande Road - Wujiang Development Zone
215200 Suzhou - CHINA
Tel. +86 512 63033668 - Fax +86 512 63005373
admin@omet.cn